

SUBJECT: F400/F410 Dual Job Feeder separation belts
(manual correction)

DATE: SEP.15.'93
PAGE: 1 of 3

PREPARED BY: S.MANO
CHECKED BY:

FROM: Copier Technical Support Group

CLASSIFICATION:

Action Required

Troubleshooting

Retrofit Information

Revision of service manual

Information only

Other

MODEL: F400/F410

The quantity of the separation belt have been changed from two to four.

Reason of the modification:

On the original printed by the laser printer, the toner may not be fused sufficiently and the image may smeared by the separation belts.

To prevent this, two more separation belts are added to widen the contacting area between the separation belts and the original so that the separation pressure is not concentrated to the narrow area.

After this modification, these separation belts are still PM parts and the replacement interval is 1PM (120k copies) as same as before this modification.

Because of this modification, the illustrations in page 7, 14, 15, 34 and 35 should be changed. The quantity of the separation belts should be doubled. There is no correction except illustrations.

Manual corrections:

Page 7 - upper illustration

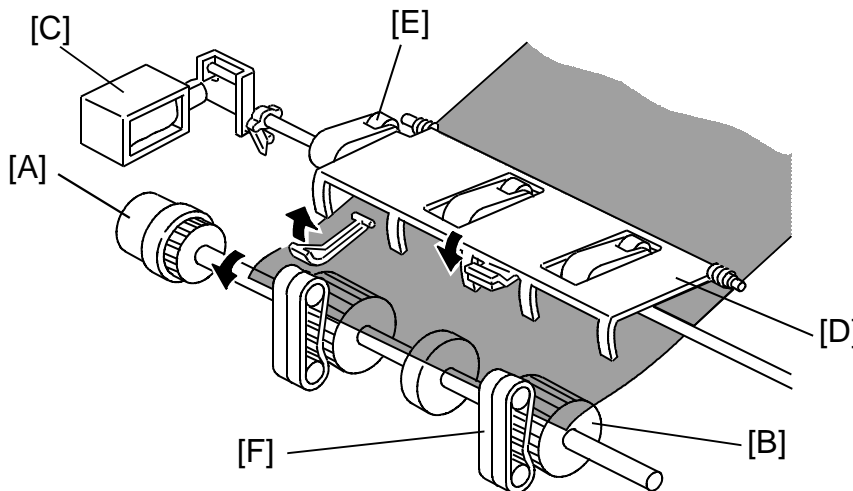

SUBJECT: F400/F410 Dual Job Feeder separation belts
(manual correction)

DATE: SEP.15.'93
PAGE: 2 of 3

Page 14 lower illustration

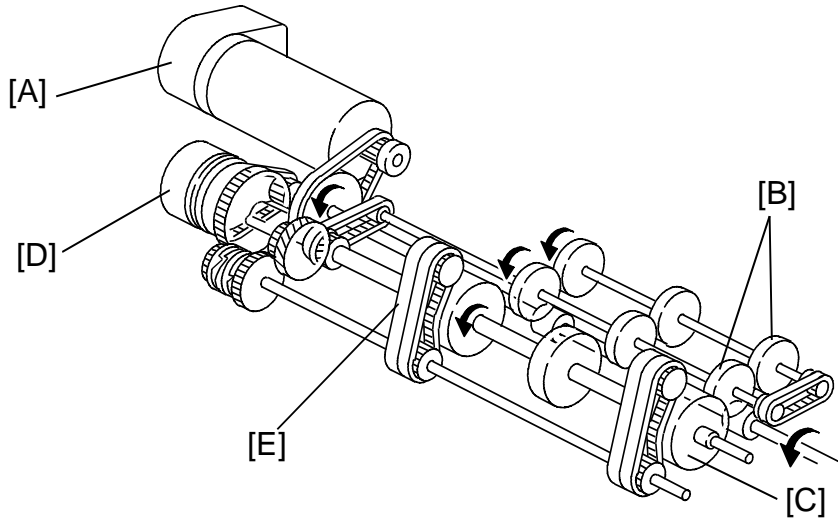

Page 15 illustration

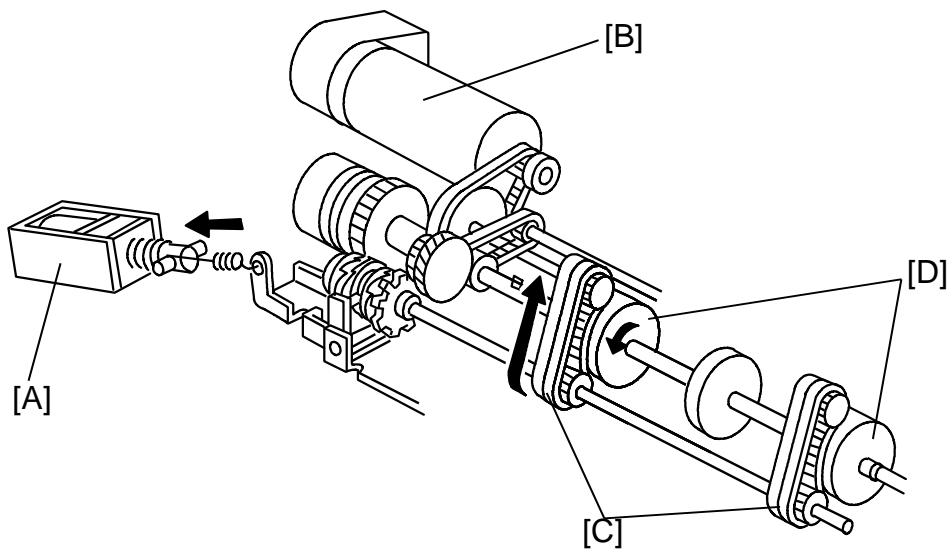

SUBJECT: F400/F410 Dual Job Feeder separation belts
(manual correction)

DATE: SEP.15.'93
PAGE: 3 of 3

Page 34 lower illustration

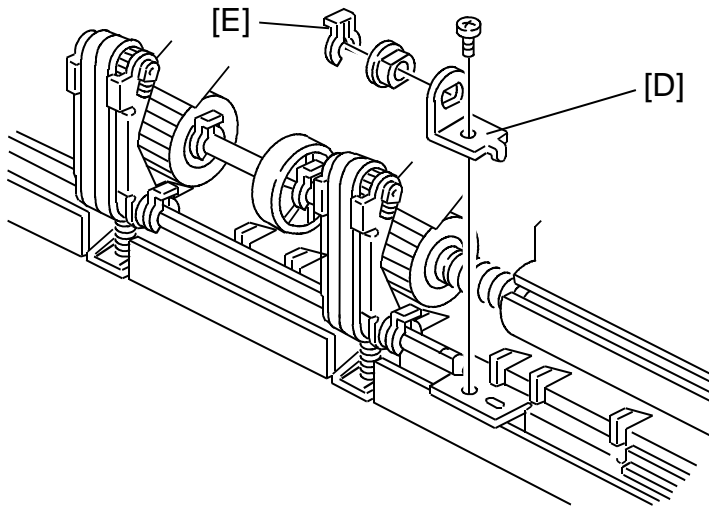

Page 35 illustrations

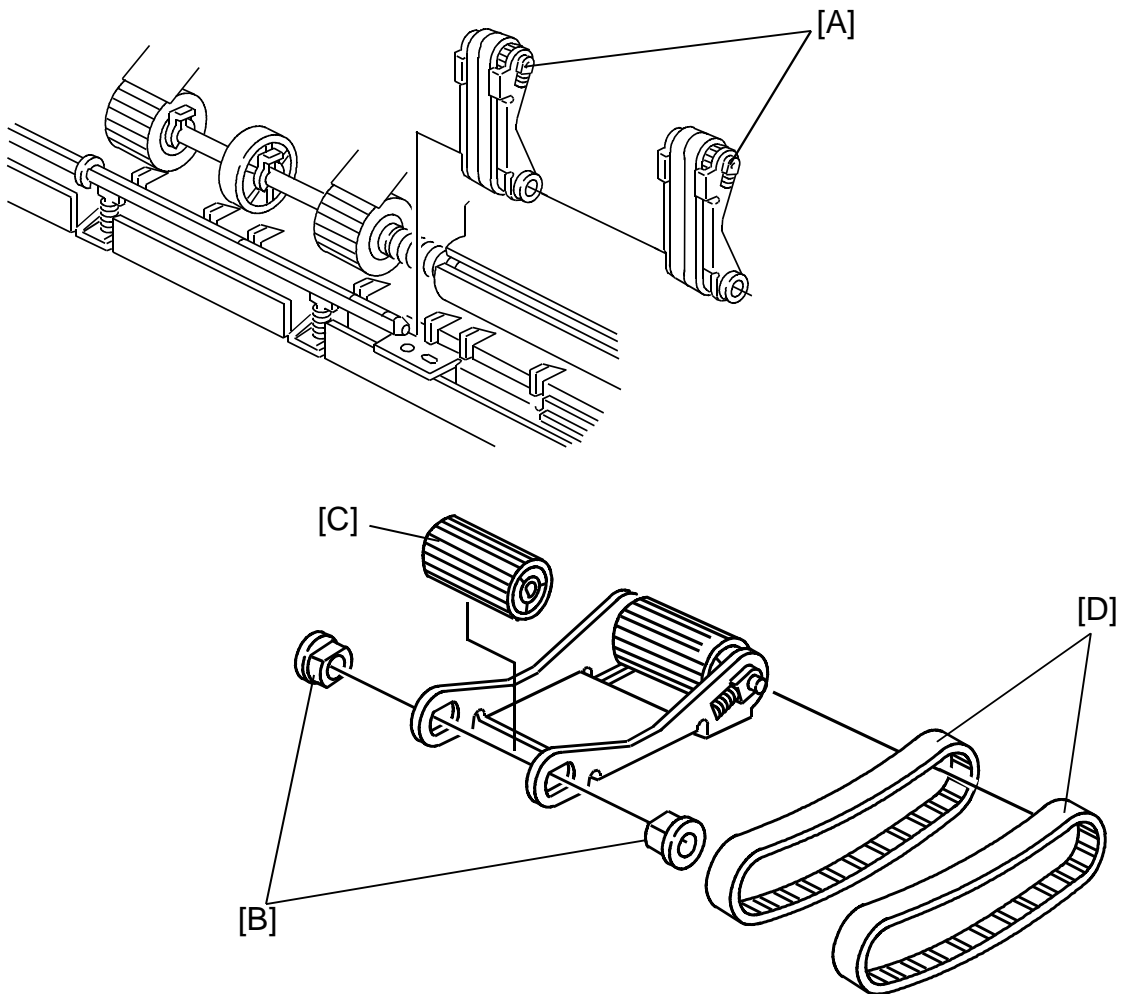

SUBJECT: F400/F410 Troubleshooting

DATE: Nov.30, '93

PAGE: 7 of 10

9. DJF Original Skew

< Phenomenon >

If original skews occur as illustrated even if the DJF height is correctly adjusted, perform the following adjustment.

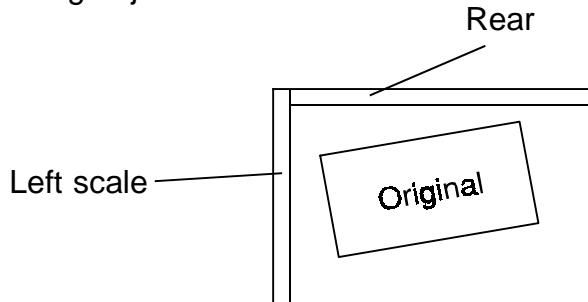

< Possible cause >

This skew is caused because the transport belt is faster than the feed-in motor speed, even if both motor speeds are within the specification.

< Countermeasure >

1. Feed-in motor speed adjustment

Adjust the feed-in motor speed so that the motor speed becomes higher (within specification).

- 1-1 Turn DIP SW 101-1, 2, 4 to "ON".
- 1-2 Turn DIP SW 102-1 to "ON".
- 1-3 Turn VR 103 towards "H" to turn LED 101 (Red) on.
- 1-4 Turn VR 103 towards "L" to turn LED 102 (Green) on.

2. Transport belt motor speed adjustment

Adjust the transport belt motor speed so that the motor speed becomes lower (within specification).

- 1-1 Turn DIP SW 101-1, 2, 4 to "ON".
- 1-2 Turn DIP SW 102-2 to "ON".
- 1-3 Turn VR 104 towards "L" to turn LED 103 (Red) on.
- 1-4 Turn VR 104 towards "H" to turn LED 102 (Green) on.

SUBJECT: DJF Multiple feeding

DATE: Nov.30, '93

PAGE: 1 of 2

PREPARED BY: S. MANO

FROM: Copier Technical Support Group

CHECKED BY:

CLASSIFICATION:

Action Required

Troubleshooting

Retrofit Information

Revision of service manual

Information only

Other

MODEL: F400/F410

< Phenomenon >

Original multiple feeding occurs when there is high friction between the originals. This tends to occur especially when the originals have staple holes, or computer forms with rough edges.

< Possible cause >

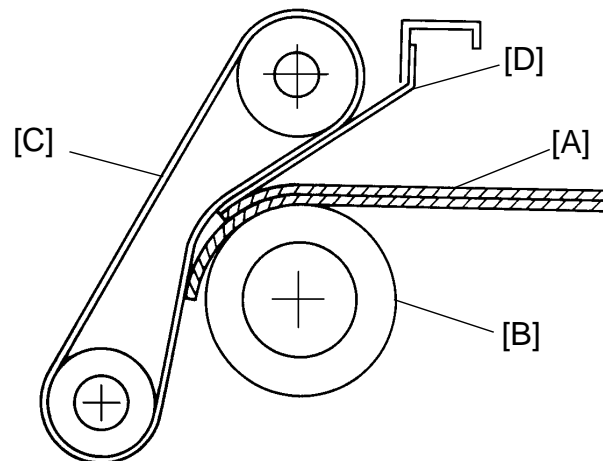

When the originals [A] comes between the feed rollers [B] and the separation belts [C], they meet the mylar [D] between them and the separation belts. This guide mylar transports the originals smoothly to the gap between the feed rollers and the separation belts. The mylar length determines the original separation force. If the mylar is longer, the area where the originals touch the separation belt becomes narrower, therefore the separation force become weaker. If the mylar is shorter, the separation force becomes stronger. (If it is too short, too much separation force stops original feed)
As a result of our investigation, we found that making the mylar 2mm shorter is the best condition (higher separation ability without feeding error).

SUBJECT: DJF Multiple feeding

DATE: Nov.30, '93

PAGE: 2 of 2

< Countermeasure >

Replace the original guide mylars (2 mylars per machine). New part is the assembled part of the mylar and the bracket. New part number is A3761254.

For the cut-in serial number, please refer to the modification bulletin which will be issued soon.

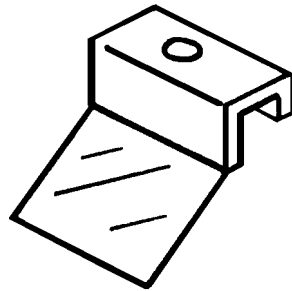

Guide mylar ass'y : Part number A3761254

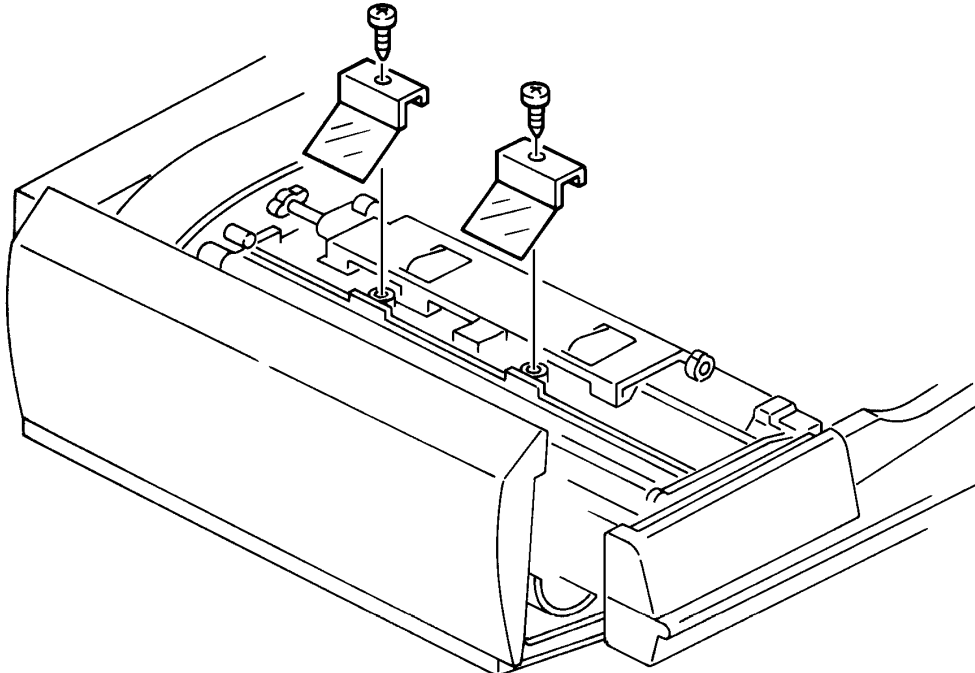

SUBJECT: Installation procedure

DATE: Nov. 30, '93

PAGE: 2 of 3

3. Caution for DJF shipping tape removal (dual job feeder service manual - installation procedure page, 24)

When removing the tape [B] fixing the original press roller shaft [C], be careful to confirm that the shaft is correctly in the holder [D]. It is possible that the shipping tape adheres strongly to the shaft. The shaft might be pulled out from the holder when the tape is removed.

If the shaft is out of position, the original will not feed.

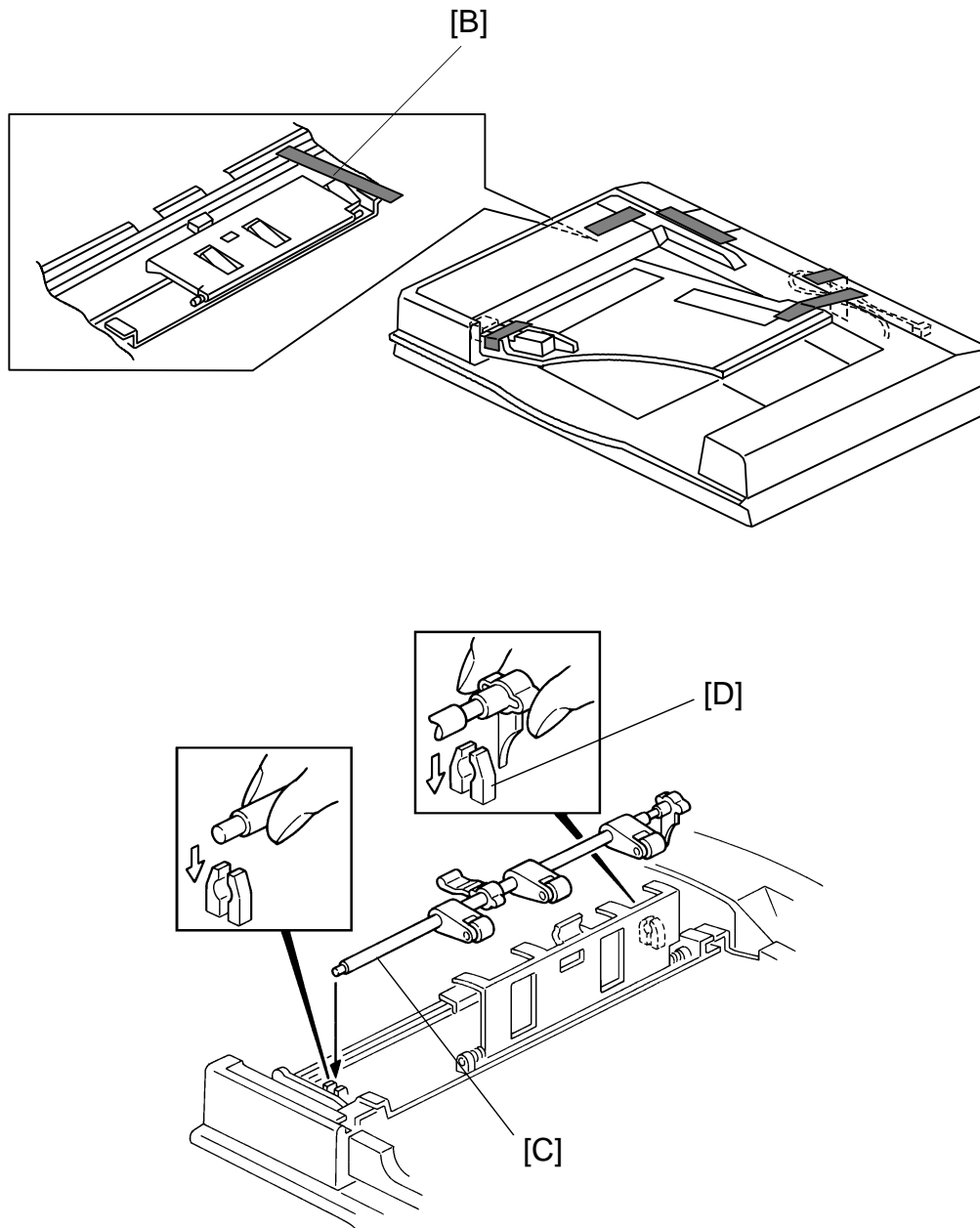

SUBJECT: DJF feed roller assembly replacement

DATE: Nov.30, '93

PAGE: 1 of 3

PREPARED BY: S.MANO

FROM: Copier Technical Support Group

CHECKED BY:

CLASSIFICATION:

Action Required

Troubleshooting

Retrofit Information

Revision of service manual

Information only

Other

MODEL: F400/F410

1. Manual correction

In the feed roller replacement procedure (page 32 to 33), there are steps asking to remove the original table and original guide. Actually, this procedure is not necessary. Please skip steps 2, 3, 4, and 5. You can directly access the feed roller.

2. Procedure change due to modification.

In the domestic market, we have experienced that the customer took off the feed roller assembly [A] when removing a jammed original. When the jammed original is pulled to the front, the feed rollers are pulled to the front and the joint part [B] comes out from the drive shaft. To prevent this, The middle roller [C] position has been changed (to the rear) as shown below.

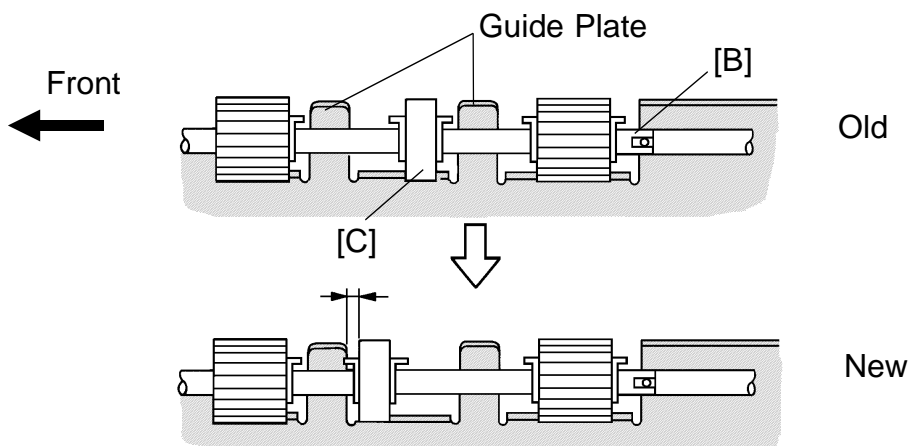
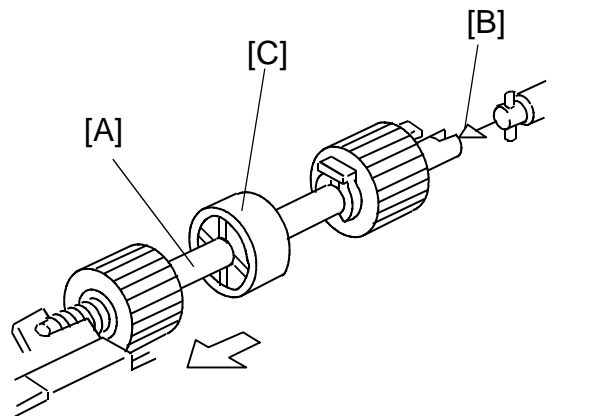

SUBJECT: DJF feed roller assembly replacement

DATE: Nov.30, '93
PAGE: 2 of 3

Before the modification, the middle roller could be shifted to the front when the feed roller was pulled to the front. After the modification, when the feed roller is pulled to the front, the middle roller hits the guide plate and it cannot be moved to the front. This prevents the joint part from being separated by mistake.

To replace the feed roller assembly, the following procedure is necessary before performing step 6 (slide the feed roller assembly to the front, then remove it).

- * Remove the guide mylars
- * Remove the snap ring.
- * Hold the feed roller.

After the modification, procedure "14.2 feed roller replacement" is changed as shown in next page.

SUBJECT: DJF feed roller assembly replacement

DATE: Nov.30, '93
PAGE: 3 of 3

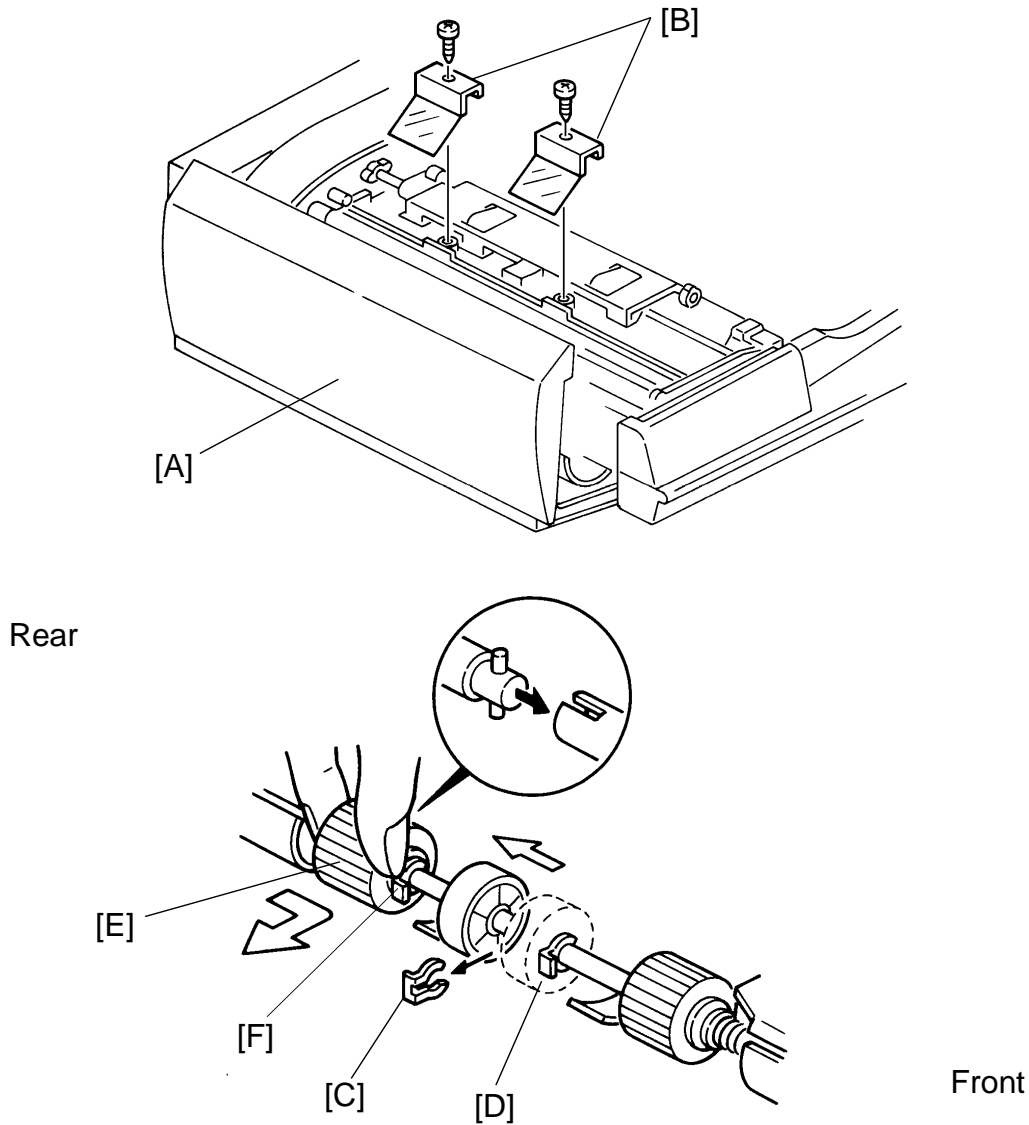

1. Turn off the main switch then open the feed cover [A].
2. Remove the guide mylars [B] (1 screw each).
3. Remove the snap ring [C].
4. Slide the roller [D] to the rear.
5. Hold the feed roller [E] then slide the shaft to the front, then remove the feed roller assembly as shown.
6. Remove the four snap rings [F], then remove the feed rollers.
7. Install the new feed rollers, then re-assemble the machine.

SUBJECT: DJF VERTICAL REGISTRATION ADJUSTMENT FOR TWO SIDED ORIGINAL MODE**DATE: Jan. 31, '93
PAGE: 1 of 3****PREPARED BY: S. MANO
CHECKED BY:****FROM: Copier Technical Support Section****CLASSIFICATION:** Action Required Troubleshooting Retrofit Information Revision of service manual Information only Other**MODEL:**

F400/F410

DUAL JOB FEEDER

Dual job feeders with the following serial numbers have the possibility that the vertical registration for two sided original mode is improper due to insufficient inspection during production.

Machine Code	From	To
A376-15	first production	4123110190
A376-17	A3383100001	A338310674
A376-22	5323100001	5323110149
A376-26	3D81030001	3D81130040
A376-27	A3383100921	A3383111103

A376-10 No machine

If necessary, please adjust the vertical registration (refer to page 46 of the DJF service manual).

If the vertical registration adjustment cannot be carried out using the procedure on page 46 of the DJF service manual (by using SP adjustment mode), return the SP adjustment data to "00".

Then adjust the vertical registration by turning VR102 on the DJF main board. The VR102 adjustment has a wider adjustable range than SP adjustment mode (adjustable range by SP adjustment: -7.5 mm ~ +7.5 mm, 0.5mm/step).

SUBJECT: DJF VERTICAL REGISTRATION ADJUSTMENT FOR TWO SIDED ORIGINAL MODE

DATE: Jan. 31, '93
PAGE: 2 of 3

Two Sided Original Mode

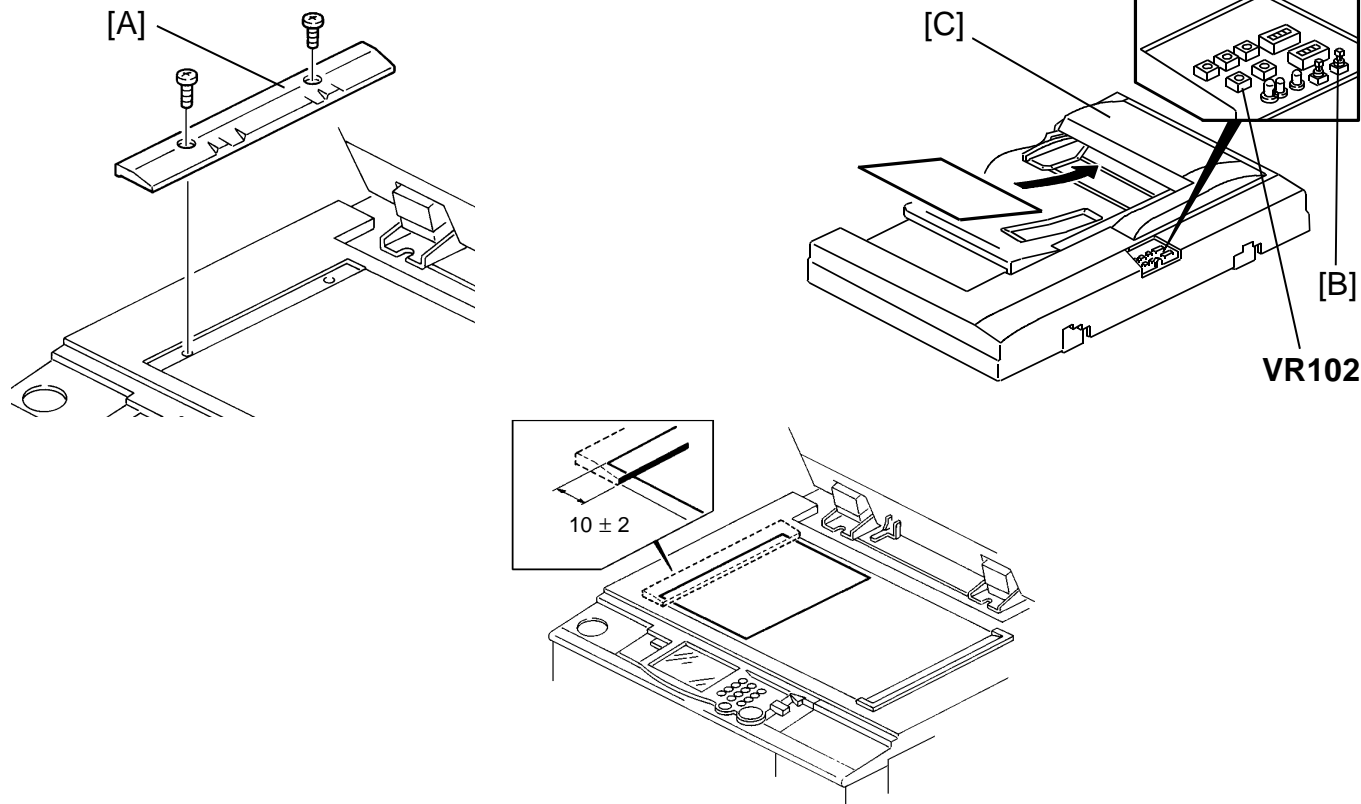

1. Remove the copier's left scale [A] (2 screws).
2. Remove the small cover at the rear side on the upper DJF cover then turn on DIP SW 101-2, 101-4, and 102-1.
3. Set a sheet of A4 / 8 1/2" x 11" (53 ~ 80 g/m² / 14 ~ 22 lb) paper sideways on the original table.
4. Push SW 101 [B].
5. After the original stops on the exposure glass, gently raise the DJF (so that the original does not move).
6. Confirm that the gap between the trailing edge of the paper and the left edge [C] of the original rear scale is 10 ± 2 mm.
7. If the gap is not within specification, adjust the registration by using the copier SP mode (SP Adjustment - PAGE 6).

NOTE:

1. Before setting the original on the original table again, open and close the feed unit cover [C].
2. After completing the adjustment, return the DIP switches to their original condition.

SUBJECT: DJF VERTICAL REGISTRATION ADJUSTMENT FOR TWO
SIDED ORIGINAL MODE

DATE: Jan. 31, '93
PAGE: 3 of 3

8. If the registration cannot be adjusted even though the SP data is changed to the maximum value, return the data to "00".
9. Adjust the vertical adjustment by turning VR102 on the DJF main board.

SUBJECT: MANUAL CORRECTIONS

DATE: Jan. 31,'94

PAGE: 9 of 13

Page 6-19 1.15

- Incorrect

1.15 DUAL JOB FEEDER

Definition: [Level:B]

Encoder pulse is not detected by the DJF main board.....

Possible causes

DJF feed motor defectiveDJF transport motor defectiveDJF feed out motor defectiveDJF inverter motor defective

- Correct

1.15 DUAL JOB FEEDER/RECIRCULATING DOCUMENT HANDLER

Definition: [Level:B]

Encoder pulse is not detected by the DJF/RDH main board.....

Possible causes

DJF/RDH feed motor defectiveDJF/RDH transport motor defectiveDJF/RDH feed out motor defectiveRDH inverter motor defective**Page 11 of DJF Illustration**

- Incorrect

In Fig.2, the left paper is expressed by a dotted line and the right paper is expressed by solid line.

- Correct

In Fig.2, the left paper position is shown by a solid line and the right paper position is shown by a dotted line as shown.

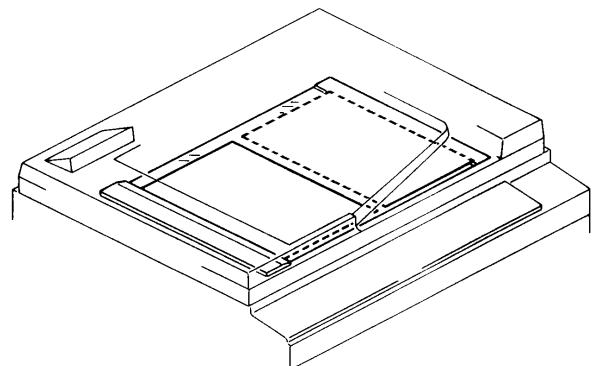

SUBJECT: MANUAL CORRECTIONS

DATE: Jan. 31,'94

PAGE: 10 of 13

Page 12 of DJF 3rd line of [Figure 3] explanation

- Incorrect
A few pulses (0 ~ 14 pulses: depends on the SP mode adjustment)
- Correct
A few pulses (0 ~ 14 pulses: depends on the DIP switch adjustment)

Page 27 of DJF 3rd line of upper NOTE and Illustration

- Incorrect
..... loosen four truss head screws [D], and tighten.

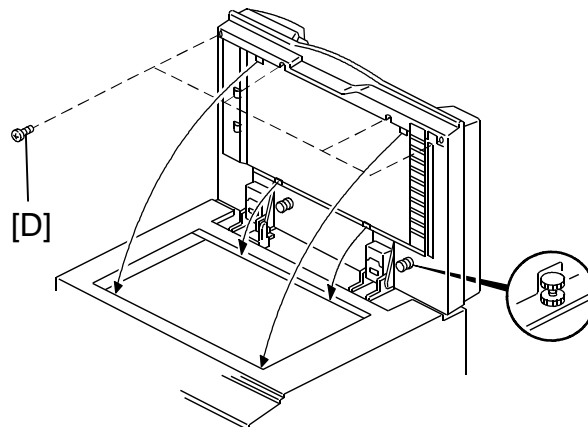

- Correct
..... remove the cover [D] (4 screws), and loosen then tighten 4 screws [E].

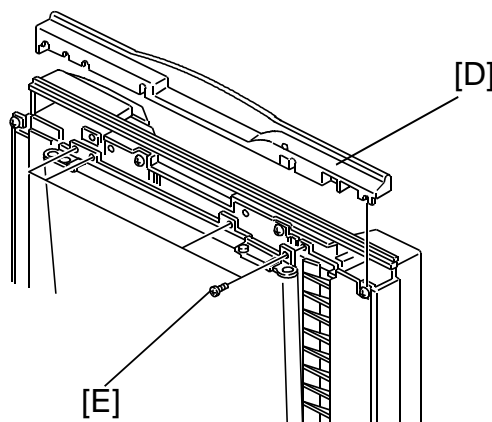

SUBJECT: MANUAL CORRECTIONS

DATE: Jan. 31,'94

PAGE:11 of 13

Page 43 of DJF Illustration

- Incorrect

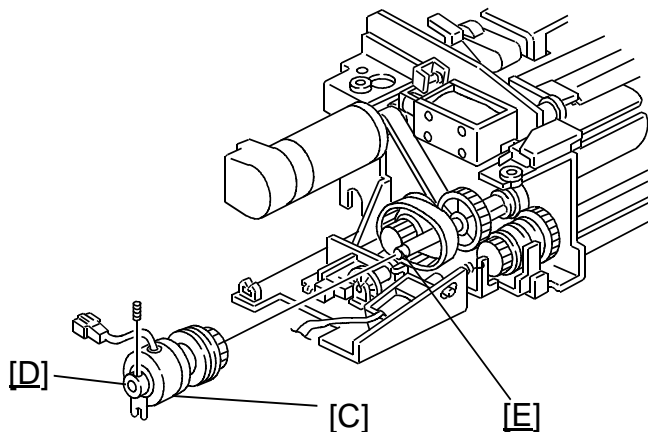

- Correct

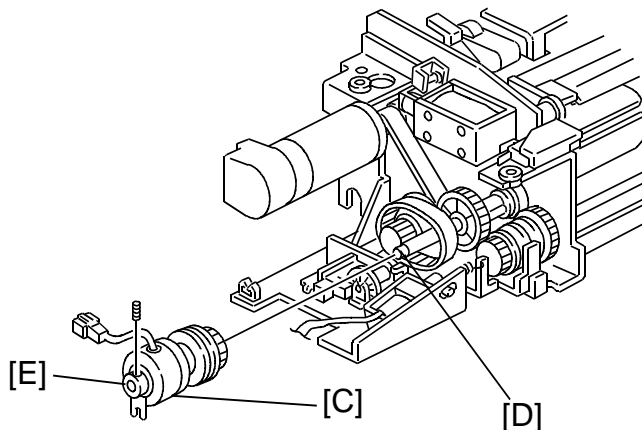

Page 46 of DJF Step 6

- Incorrect

6. Confirm that the gap between the trailing edge of the paper and the left edge [C] of the original rear scale is 10 ± 2 mm.

- Correct

6. Confirm that the gap between the trailing edge of the paper and the right edge of the original rear scale is 10 ± 2 mm.

SUBJECT: Manual Correction

DATE:
February. 15, 1994
PAGE: 1 of 2

PREPARED BY: S. Mano
CHECKED BY:

FROM: Copier Technical Support Section

CLASSIFICATION:

Action Required

Troubleshooting

Retrofit Information

Revision of service manual

Information only

Other

MODEL: F400 DJF

MANUAL CORRECTION

Page 4-59 DUAL JOB FEEDER Preventive Maintenance Schedule

Incorrect

	EM	120K	240K	360K	NOTE
DUAL JOB FEEDER (for originals)					
Transport Belt	C	R	R	R	Belt cleaner. Replace if necessary.
Pick-up Roller	C	C	C	C	Alcohol. Replace if necessary.
Feed Roller	C	R	R	R	Alcohol. Replace if necessary.
Separation Belts	C	R	R	R	Alcohol. Replace if necessary.

Correct

	EM	120K	240K	360K	NOTE
DUAL JOB FEEDER (for copies)					
Transport Belt	C	R	R	R	Belt cleaner. Replace if necessary.
Pick-up Roller	C	C	C	C	Alcohol. Replace if necessary.
Feed Roller	C	R	R	R	Alcohol. Replace if necessary.
Separation Belts	C	R	R	R	Alcohol. Replace if necessary.

SUBJECT: Manual correction

DATE:
February 15, 1994
PAGE: 2 of 2

Each parts's actual estimated life is 48K original feed times.

Since estimated average copies per one original is 2.5, we recommend to replace the transport belt, separation belts and feed roller at the same time as the copier's 120K PM.

(48,000 x 2.5 = 120,000)

Because the F400/F410 series has an SP mode PM counter (indicates the original feed time since the last PM), you can recognize how many times originals have been fed since the last PM parts replacement. We recommend utilizing this function to manage the PM parts replacement interval.

Therefore, if you utilize PM counter for original feed (9 PM COUNTER CLEAR PAGE4), the PM table is as follows:

	EM	48K	96K	144K	NOTE
DUAL JOB FEEDER (for originals)					
Transport Belt	C	R	R	R	Belt cleaner. Replace if necessary.
Pick-up Roller	C	C	C	C	Alcohol. Replace if necessary.
Feed Roller	C	R	R	R	Alcohol. Replace if necessary.
Separation Belts	C	R	R	R	Alcohol. Replace if necessary.

Concerning the RDH, the copy volume and original feed times are almost the same.

We just recommend to replacing PM parts at the same time as the copier's 120K PM (transport belt: replace at every copier's 240K PM).

SUBJECT: DJF ORIGINAL DOUBLE FEEDING

DATE: Mar. 15 '94

PAGE: 1 of 2

PREPARED BY: S. MANO
CHECKED BY: S. Hamano

FROM: 2nd Technical Support Section

CLASSIFICATION:

- Action Required
- Troubleshooting
- Retrofit Information

- Revision of service manual
- Information only
- Other



MODEL:DJF for F400 series

Phenomenon

Original double feeding (two originals are fed at a time) tends to occur when the separation belts [A] become dirty with foreign matter which being transferred from the original surface.

Cause

When the separation belt surface is covered with foreign matter, the friction between the original and the separation belt decreases. This reduces the original separation ability.

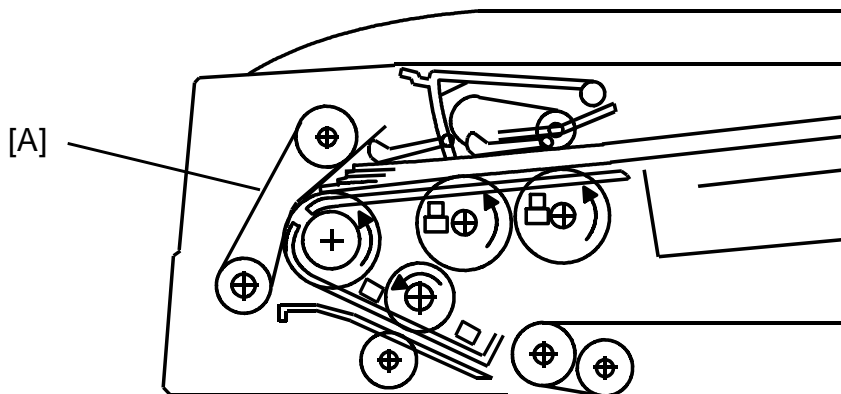
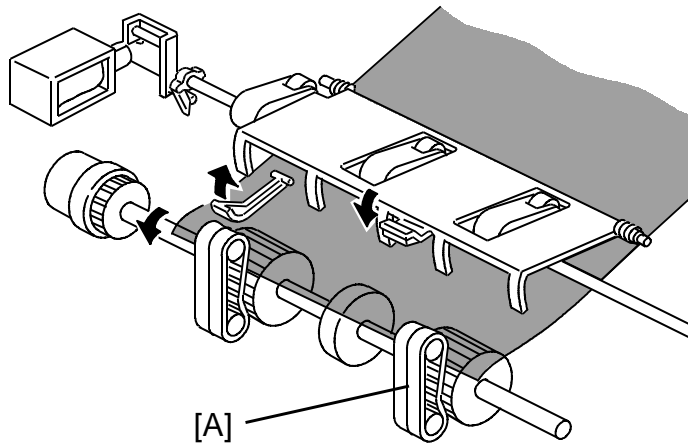

SUBJECT: DJF ORIGINAL DOUBLE FEEDING

DATE: Mar. 15 '94

PAGE: 2 of 2

Countermeasure

Clean the separation belt surface with alcohol to recover the separation ability. We recommend to do this **at every customer visit** including at the installation to eliminate further EM calls.

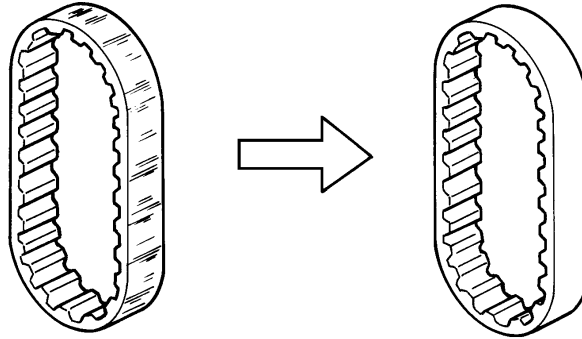

Note: If block original feeding (10~20 sheets of originals are fed at a time) occurs, replace the original guide mylars [A] to the new parts (A3761254). Please refer to RTB-008 for the details.

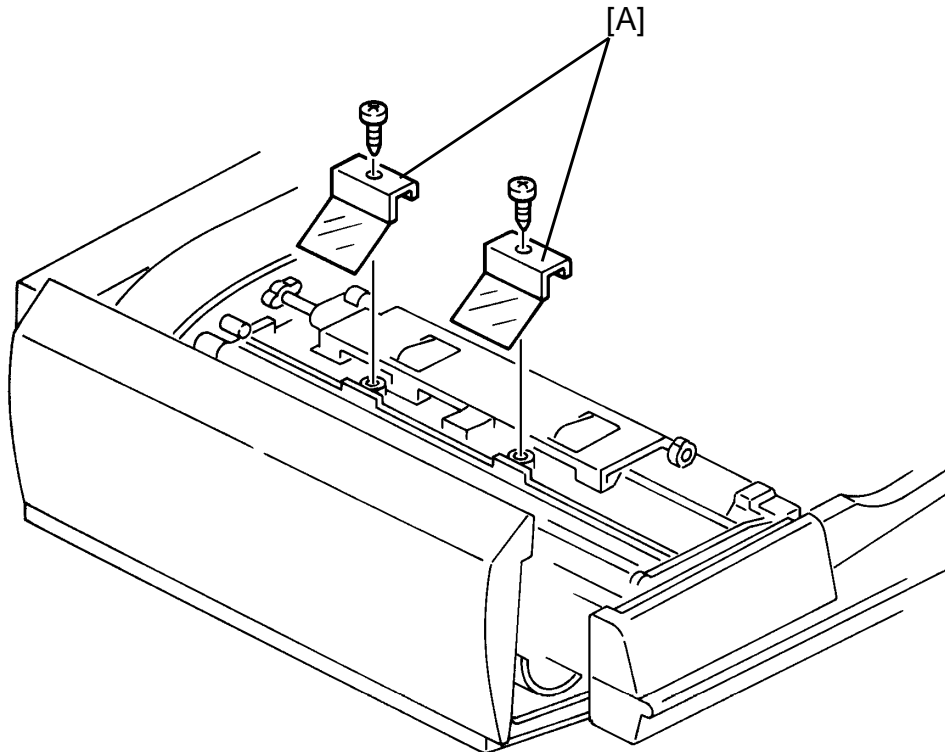

SUBJECT: Irregular original stack in auto counting mode

DATE: April 30, '94

PAGE: 1 of 2

PREPARED BY: S. MANO
CHECKED BY: S. Hamano

FROM: 2nd Technical Support Section

CLASSIFICATION:

- Action Required
- Troubleshooting
- Retrofit Information

- Revision of service manual
- Information only
- Other

MODEL: F400 / F410

<PHENOMENON>

During auto counting mode, the original delivery speed varies. The original stack alignment become irregular, and in the worst case, the original order changes.

This problem specially occurs when feeding letter (8 1/2" x 11") sideways originals.

<PHENOMENON>

When the original is delivered in auto counting mode, the original exit motor changes its speed. Just before the trailing edge of the original passes through the exit roller, its speed decreases to correct the original stack. Normally the original exit motor changes to the quicker speed after completely feeding out the original. However, sometimes, the exit motor returns to the quicker speed before the original trailing edge passes through the exit roller. In this case, the original is pushed out quickly, resulting in the irregular original stack.

SUBJECT: Irregular original stack in auto counting mode

DATE: April 30, '94

PAGE: 2 of 2

<COUNTERMEASURE>

The original stack guide mylar is added. This mylar is attached to the DJF as an accessory. Please install the mylar at installation as shown in the illustration below.

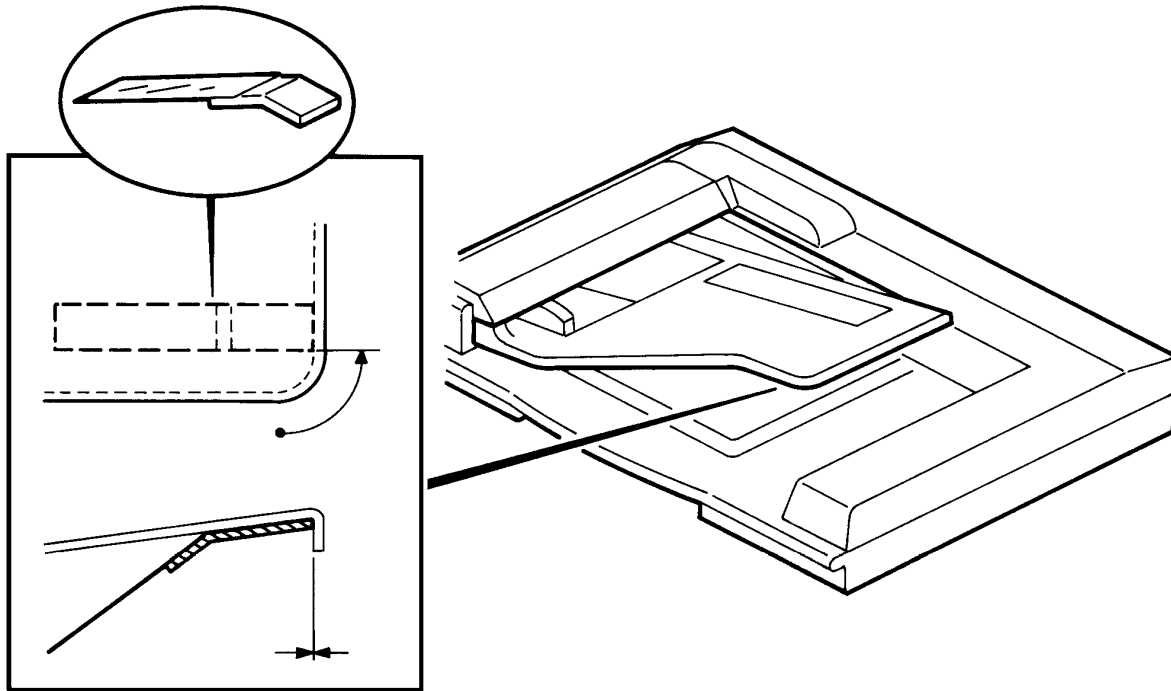

SUBJECT: ORIGINAL DOUBLE FEEDING

DATE: June 30, '94

PAGE: 1 of 2

PREPARED BY: S. MANO
CHECKED BY: S. Hamano

FROM: 2nd Technical Support Section

CLASSIFICATION:

- Action Required
- Troubleshooting
- Retrofit Information

- Revision of service manual
- Information only
- Other

MODEL: DUAL JOB
FEEDER FOR
F400/F410/F420

This is additional information of RTB-025 "DJF double feeding".

<PHENOMENON>

Original double feeding (two or more sheets of the originals are fed at a time)

<POSSIBLE CAUSE>

The separation belts become dirty with the toner, losing the friction to separate the originals.

This is especially true when the customer feeds lots of poorly fused originals such as laser output or cotton paper.

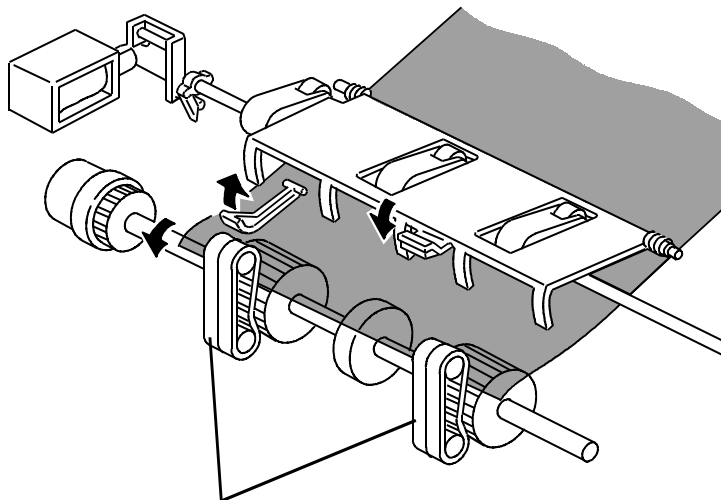

Separation Belts

SUBJECT: ORIGINAL DOUBLE FEEDING

DATE: June 30, '94

PAGE: 2 of 2

<FIELD COUNTERMEASURE>

Replace the separation belts with the new parts. The new part number is A3769502.

The material of the separation belts has been changed to the one which less toner adheres to.

NOTE: Depending on the type of originals that the customer use, there is still a possibility that the separation belts become dirty. For those cases, cleaning the belts at every visits, which was introduced in the previous RTB, is recommended.

This modification is implemented from the following serial numbers.

A376-10: 537403xxxx

A376-15: 4124030001

A376-17: A3384030001

A376-22: 5324030001

A376-26: 3D80340001

A376-27: A3384030150

As explained in RTB-008 "DJF multiple feeding", if the block original feeding (10~20 sheets of originals are fed at a time) occur, replace the original guide mylars [A] with the new parts (A3761254). Please refer to RTB-008.

This modification has been implemented from the November 1993 production (Please refer to MB No.3 of DJF for the cut-in serial numbers).

To completely eliminate the original double/multiple feeding, replace both original guide mylar (new part number A3761254) and separation belts.

SUBJECT: SOFTWARE MODIFICATION

DATE: Dec. 31, '94

PAGE: 1 of 7

PREPARED BY: S. Mano
CHECKED BY: S. Hamano

FROM: 2nd Technical Support Section

CLASSIFICATION:

-
- Action Required
-
-
- Troubleshooting
-
-
- Retrofit Information

-
- Revision of service manual
-
-
- Information only
-
-
- Other

MODEL: F400/F410

1. "A" version ROMs

From the following serial numbers, the EPROMs (A0965151 and A0965153) on the main board have been updated to version "A".

Code	Serial Number
A095-10	5204480001
A095-15	2644600001
A095-17	A3354460277
A095-22	5234050106
A095-26	3D50540001
A095-27	A3354050001
A095-29	A3354050320
A096-10	5244470002
A096-15	2844600037
A096-17	A3364460002
A096-22	5274050001
A096-26	3D60540001
A096-27	A3364050001
A096-29	A3364050096
A097-all	From the first production

The following are corrected by this software change:

1-1. Black shadow in ADF reduction mode

When the original is fed by the DJF while in reduction mode, sometimes (depending on the reproduction ratio) a black line appears on the front edge because the shadow of the original edge is erased incompletely.

SUBJECT: Sorter/DJF Installation

DATE: September 15, '95
PAGE: 1 of 2

PREPARED BY: N. Kaiya
CHECKED BY: M. Iwasa

FROM: 2nd Technical Support Section

CLASSIFICATION:

- | | |
|-----------------------------------------------------|-----------------------------------------------------|
| <input checked="" type="checkbox"/> Action Required | <input type="checkbox"/> Revision of service manual |
| <input type="checkbox"/> Troubleshooting | <input type="checkbox"/> Information only |
| <input type="checkbox"/> Retrofit Information | <input type="checkbox"/> Other |

MODEL:

DFC - α

To comply with the CE mark, it is necessary to attach five ferrite cores when installing a sorter on DFC - α . The ferrite cores have been enclosed in the screw bag of the DFC - α from September production. Please refer to the following for the installation procedure of the ferrite cores.

Additional procedure for sorter installation

Ferrite core P/N 16070418 4 pcs.
Ferrite core P/N 16070721 1 pc.

1. Turn off the main switch and unplug the machine.
2. Remove the sorter top cover (3 screws).
3. Remove the sorter rear cover (4 screws).
4. Attach the ferrite core ([A] P/N 16070721) to the DC harness as shown.

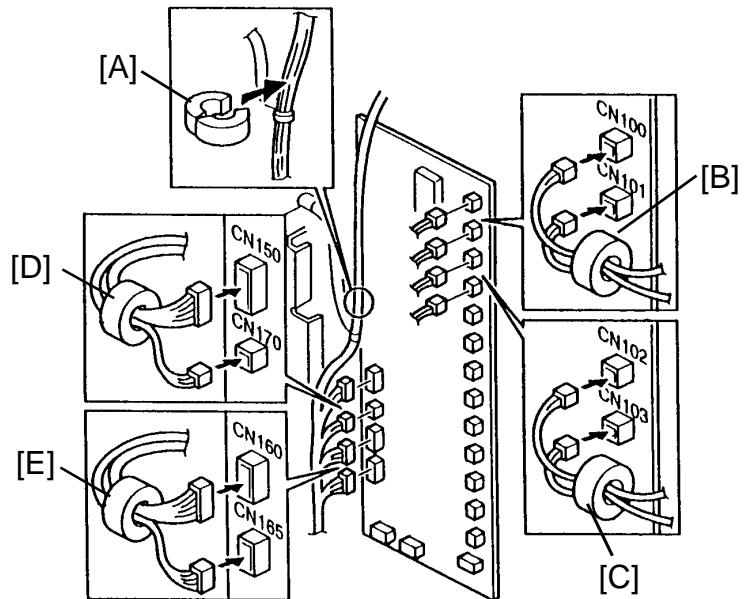

5. Remove the harnesses for second bin solenoid (CN100) and third bin solenoid (CN101). Pass the both harnesses through the ferrite core ([B] P/N 16070418) and reconnect them to the sorter main board.
6. Remove the harnesses for the fourth bin solenoid (CN102) and the fifth bin solenoid (CN103). Pass the both harnesses through the ferrite core ([C] P/N 16070418) and reconnect them to the sorter main board.
7. Remove the harnesses for the encoder (CN150) and the entry sensor LED (CN170). Pass the both harnesses through the ferrite core ([D] P/N 16070418) and reconnect them to the sorter main board.
8. Remove the harnesses for the entry sensor Phototransistor (CN160) and the inlet sensor (CN165). Pass the both harnesses through the ferrite core ([E] P/N 16070418) and reconnect them to the sorter main board.
9. Reassemble the unit.

SUBJECT: Sorter/DJF Installation

DATE: September 15, '95
PAGE: 2 of 2

Ferrite Cores Packed with DFC - α

For Sorter Installation

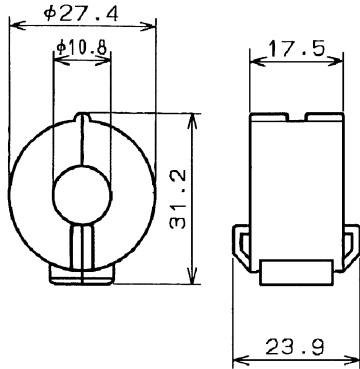

P/N 16070721

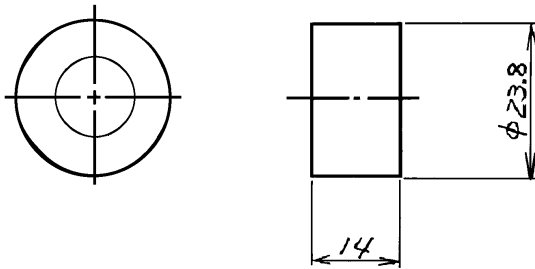

P/N 16070418

For DJF installation

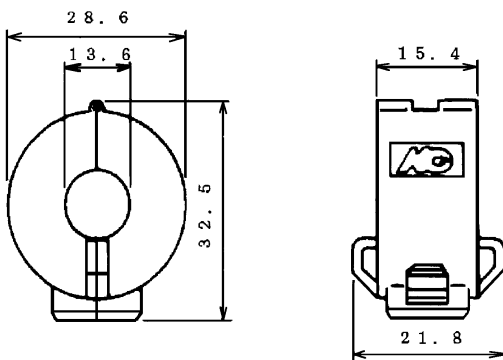

P/N 16070638

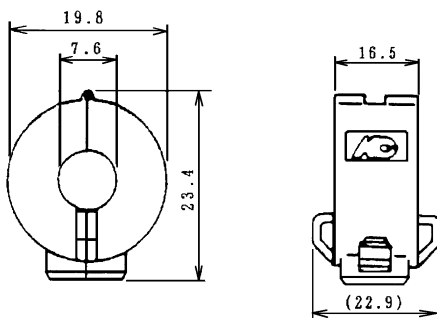

P/N 16070623